

Explanation of TVI Electronics Part Numbering System

Monochrome LCD Modules

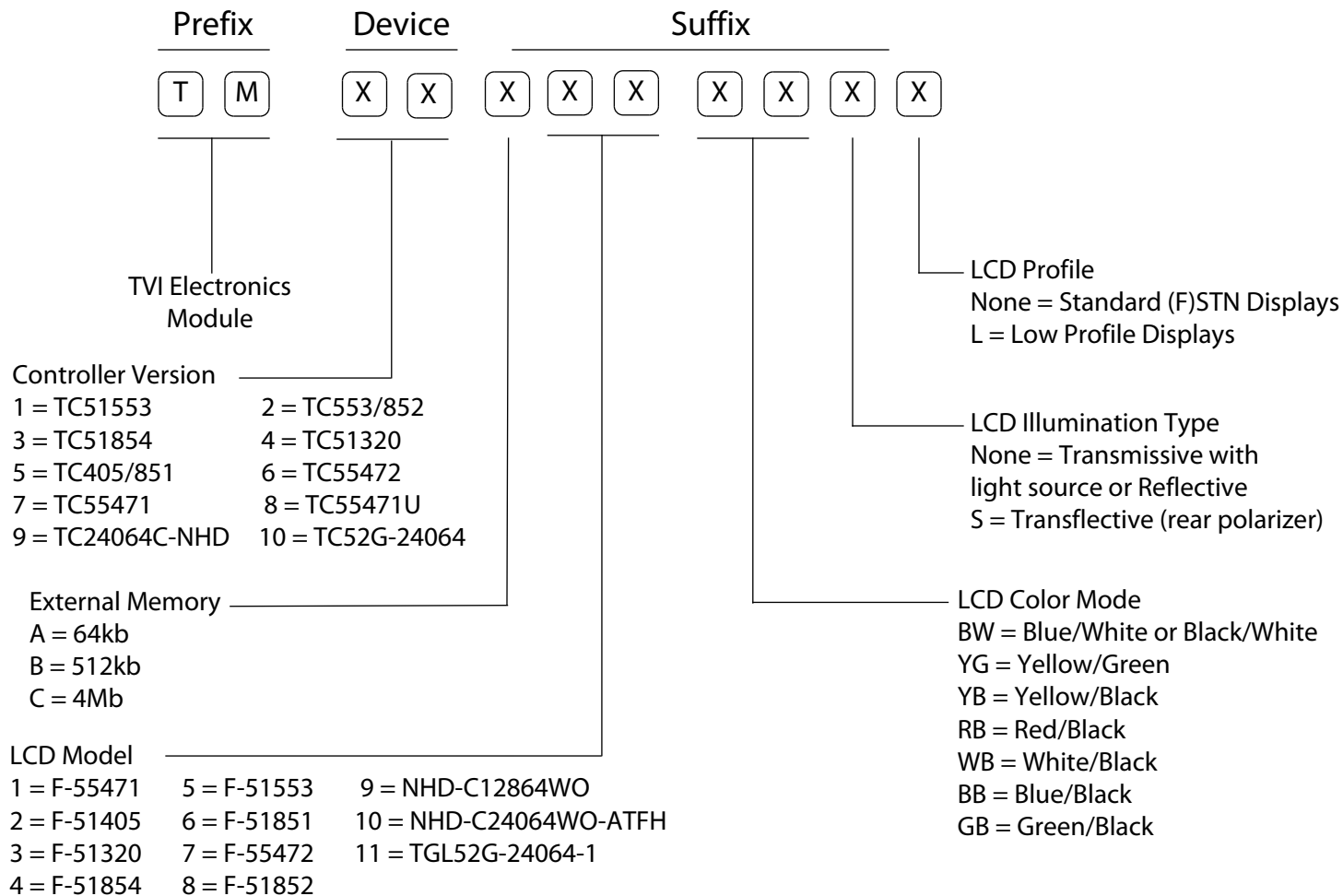

Here is an example of TVI Electronics Monochrome LCD Module part numbering:

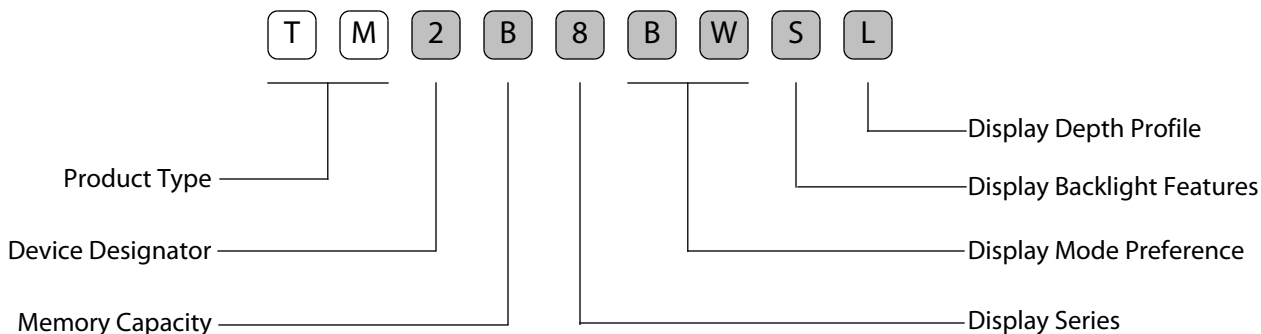

The Part Numbering Matrix Guide is used for Reference ONLY.
 TVI Electronics does not guarantee the availability of all products with combination of parameters as specified above.
 Please see details on product pages.

• All specifications and markings are subject to change without notice

Explanation of TVI Electronics Part Numbering System

Color LCD Modules

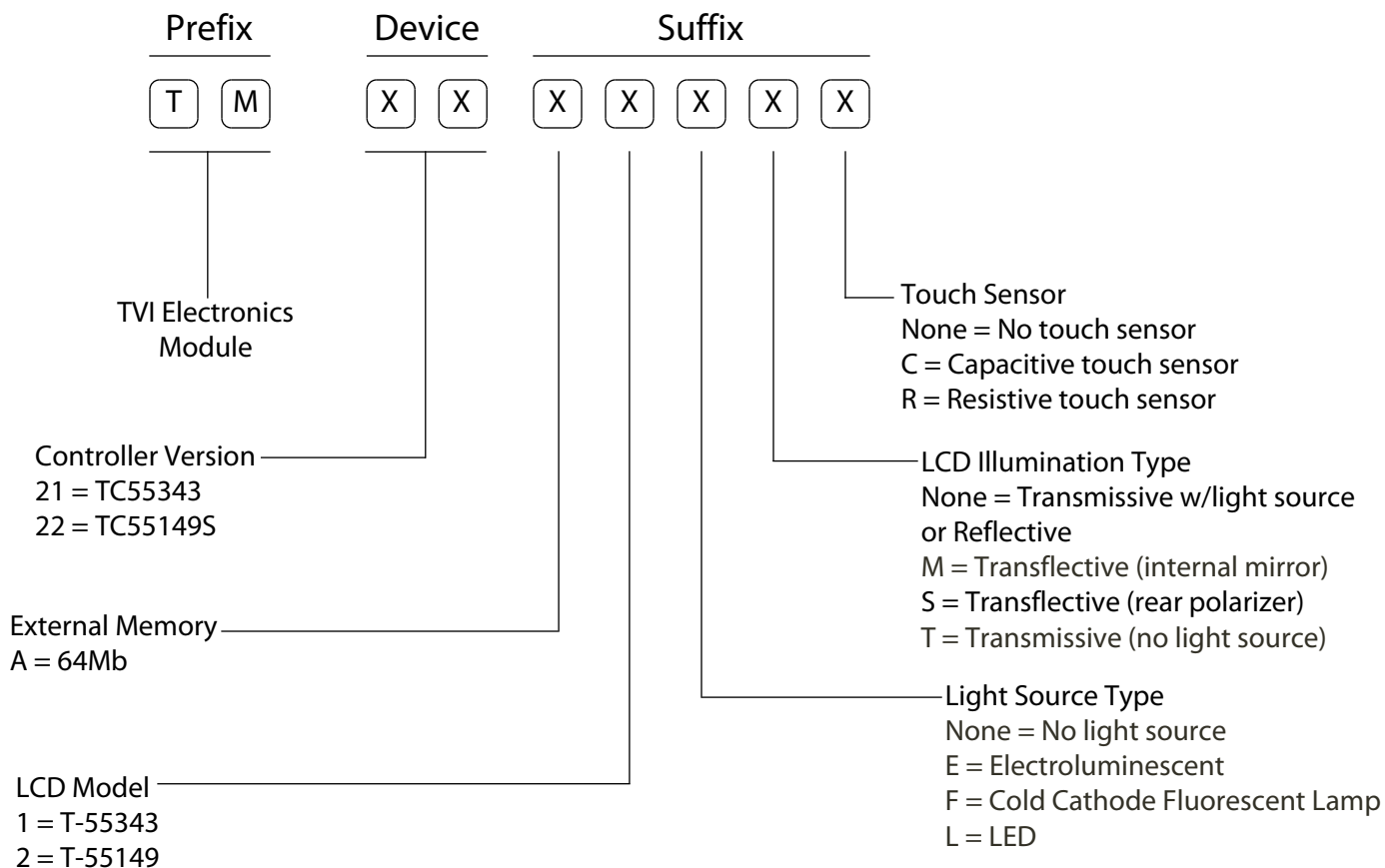

Here is an example of TVI Electronics Color LCD Module part numbering:

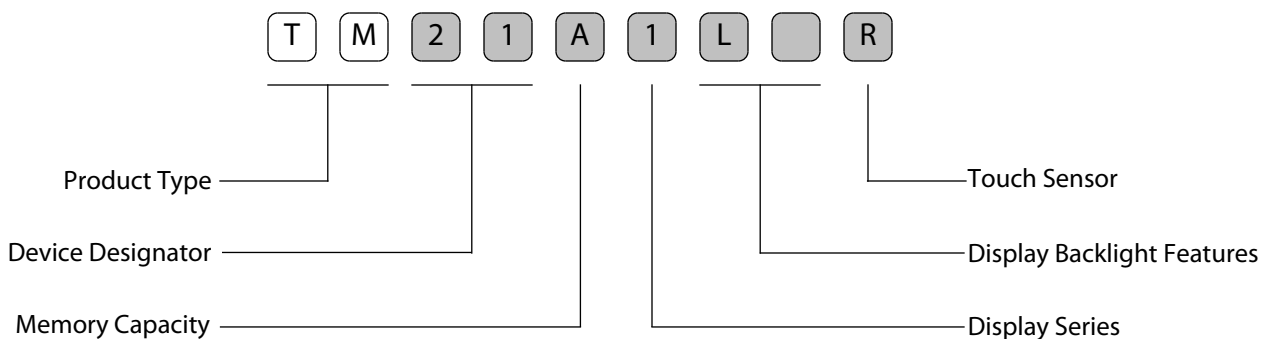

The Part Numbering Matrix Guide is used for Reference ONLY.
 TVI Electronics does not guarantee the availability of all products with combination of parameters as specified above.
 Please see details on product pages.

• All specifications and markings are subject to change without notice

Explanation of TVI Electronics Part Numbering System

Liquid Crystal Display (LCD) Solutions

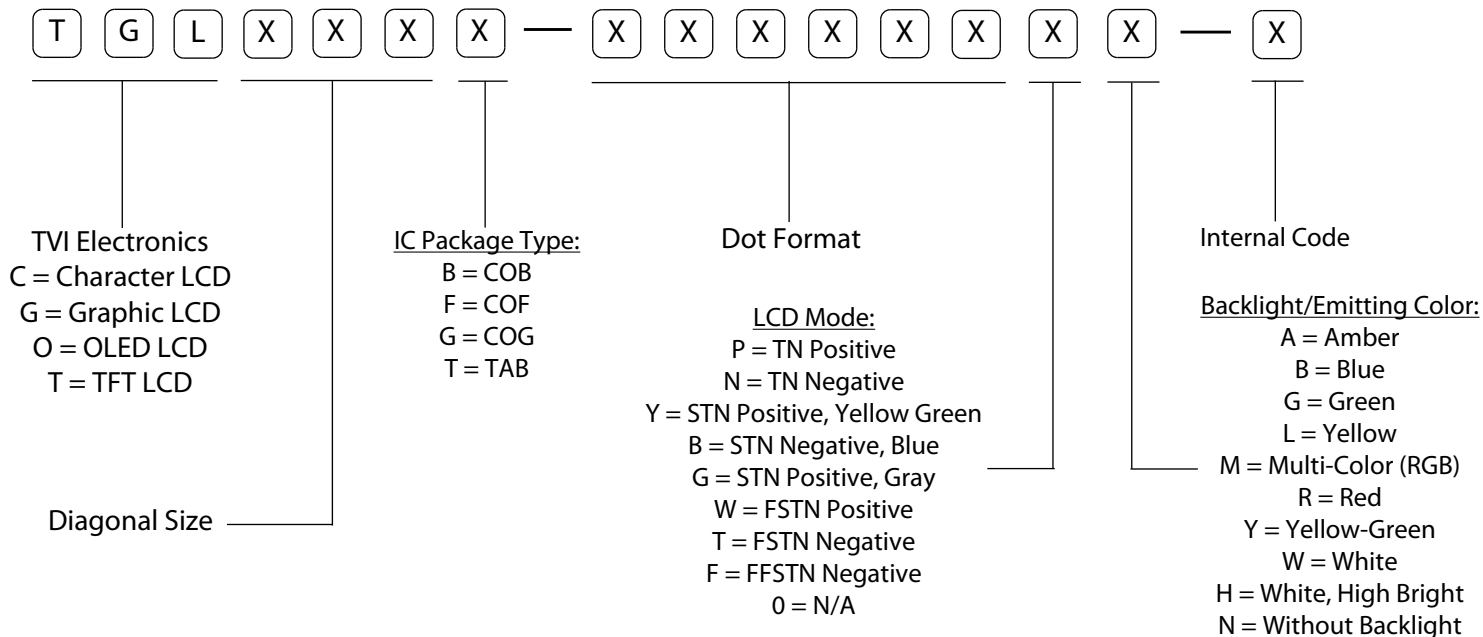

Here is an example of TVI Electronics Monochrome Graphic LCD Module part numbering:

T G L 2 9 B — 1 2 8 6 4 B W — 1

Here is an example of TVI Electronics Monochrome Character LCD Module part numbering:

T C L 1 2 G — 0 8 0 2 W B

Here is an example of TVI Electronics TFT LCD Module part numbering:

T T L 3 5 G — 3 2 0 2 4 0 0 W — 1

Here is an example of TVI Electronics OLED LCD Module part numbering:

T O L 0 6 6 G — 6 4 4 8 0 B

The Part Numbering Matrix Guide is used for Reference ONLY.
 TVI Electronics does not guarantee the availability of all products with combination of parameters as specified above.
 Please see details on product pages.

• All specifications and markings are subject to change without notice

Explanation of TVI Electronics Part Numbering System

Arduino Shield with LCD Assembly

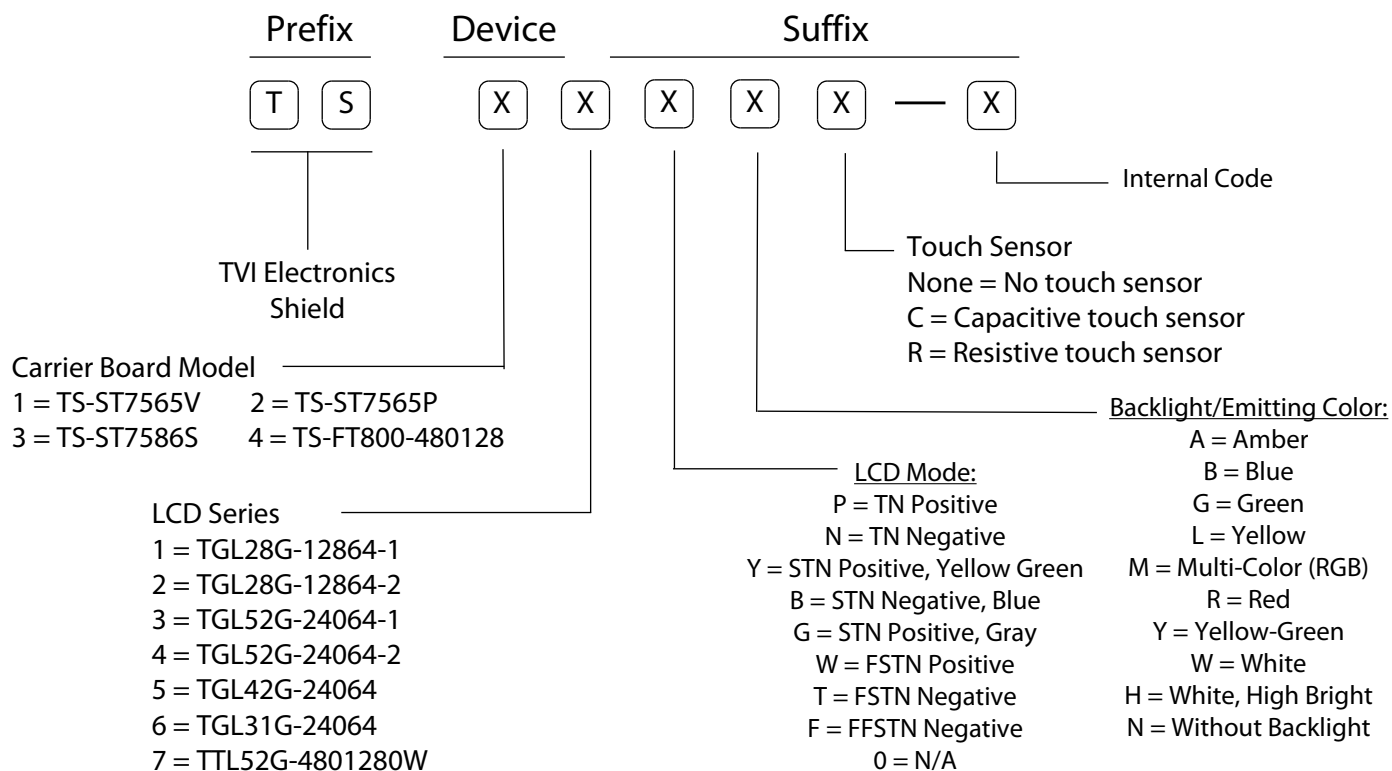

Here is an example of TVI Electronics Shield Assembly part numbering:

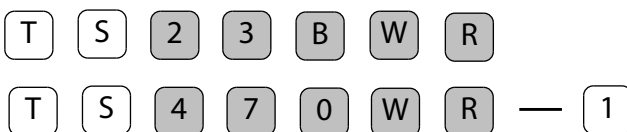

The Part Numbering Matrix Guide is used for Reference ONLY.
TVI Electronics does not guarantee the availability of all products with combination of parameters as specified above.
Please see details on product pages.

• All specifications and markings are subject to change without notice